

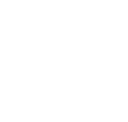

**SWP**  
Water Pumps



Monoblock centrifugal pumps



## Approvals



## 2DCM-Pump

- 1- Cast Iron Pump body
- 2- Stainless steel /Brass impeller
- 3- AISI 304 shaft
- 4- Max Liquid temperature: +60°C



## Electric Motor

- 1- C & U bearing
- 2- Motor with copper winding
- 3- Built-in thermal protector for single phase motor
- 4- Insulation class : B
- 5- Protection Class: IP44
- 6- Max ambient temperature: +40° C

PUMP TYPE	POWER		INLET/OUTLET	MAX.FLOW L/min	MAX.HEAD m	G.W kg	PACKING DIMENSION mm	QTY set
	Kw	HP						
2DCM25/140M	1.1	1.5	1.5"x1"	160	47	20.5	400x210x235	1020
2DCM25/140H	1.1	1.5	1.25"x1"	110	54	20.5	400x210x235	1020
2DCM160/160	1.5	2	1.25"x1"	125	66	25	430x235x280	880
2DCM25/160B	1.5	2	1.5"x1"	150	55	25	430x235x280	880
2DCM25/160A	2.2	3	1.5"x1"	180	66	27	510x280x330	620

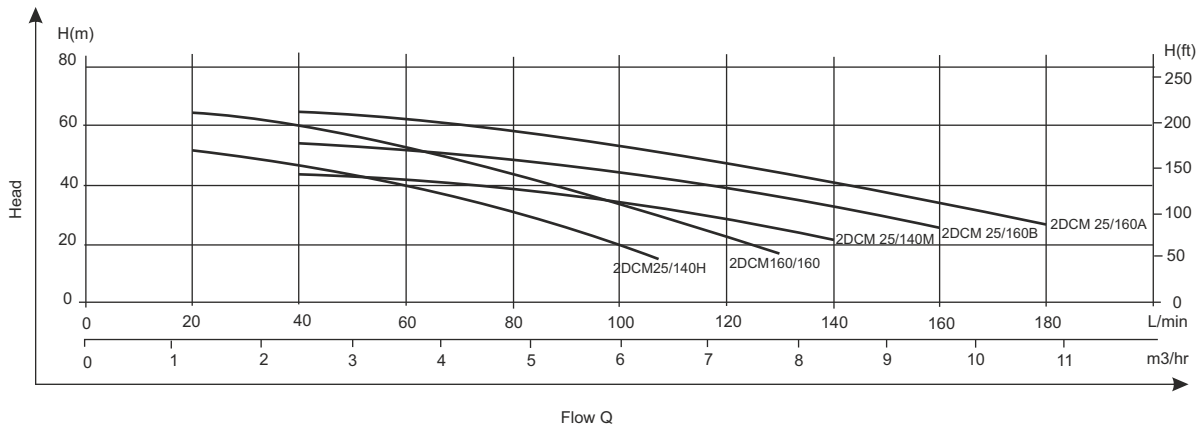

## Structure

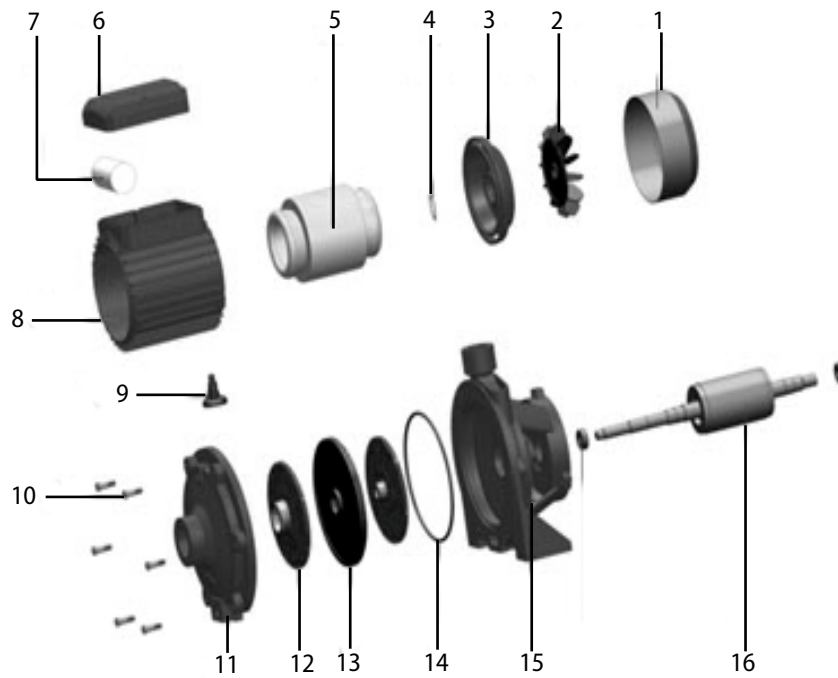

NO.	NAME	NO.	NAME
1	Fan Cover	10	Hexagon headed bolt
2	Fan	11	Pump Cover
3	Rear end Cover	12	Impeller
4	Wave washer	13	Baffle Plate
5	Stator	14	O Ring
6	Capacitor cover	15	Pump Body
7	Capacitor	16	Bearing
8	Base	17	Rotor
9	Arm-Brace		